

SIEMENS

SUPERMOON

Powering modern work and life

Order at 訂貨熱線 :

香港批發 / 分銷 T (852) 2781 2855

澳門批發 / 分銷 T (853) 2822 2751

工程 / 商業項目 T (852) 2691 9166

E enquiry@supermoon.hk

www.supermoon.hk



SINAMICS V20

The cost-effective, reliable and easy-to-use inverter for basic applications

Drives

siemens.com/sinamics-v20

SINAMICS V20

The perfect solution for basic applications

SINAMICS V20, the versatile inverter for basic demands

Today, in an increasing number of applications in plant and machinery construction, individual automation and drive solutions are demanded that automate simple motion sequences with low associated requirements.

With its compact SINAMICS V20, the basic performance inverter, Siemens offers a simple and cost-effective drive solution for these types of applications. SINAMICS V20 sets itself apart with its quick commissioning times, ease of operation, robustness and cost-efficiency.

With five frame sizes, it covers a power range extending from 0.12 kW up to 30 kW (1/6 hp up to 40 hp).

Minimize your costs

Engineering, commissioning and operating costs as well as those in operation must be kept as low as possible. You have precisely the right answer with our SINAMICS V20. To increase energy efficiency, the inverter is equipped with a control technique to achieve optimum energy efficiency through automatic flux reduction. Not only this, it displays the actual energy consumption and has additional, integrated energy-saving functions. This allows energy consumption to be slashed drastically.

Highlights

Easy to install

- Push-through and wall mounting – side-by-side possible for both
- USS and Modbus RTU at terminals
- Integrated braking chopper for 7.5 kW to 30 kW (10 hp up to 40 hp)

Easy to use

- Parameter loading without power supply
- Integrated application and connection macros
- Keep Running Mode for uninterrupted operation
- Wide voltage range, advanced cooling design and coated PCBs increase robustness

Easy to save money

- ECO mode for V/f, V²/f
- Hibernation mode
- DC coupling
- High overload and low overload mode for FSE

Power range	0.12 kW to 30 kW (1/6 hp up to 40 hp)
Voltage range	1AC 200 V ... 240 V (-10% / +10%) 3AC 380 V ... 480 V (-15% / +10%)
Control modes	V/f V ² /f FCC V/f multi-point



Typical applications

Pumping, ventilating and compressing

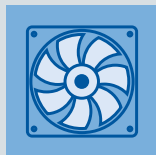

- Centrifugal pumps
- Radial/axial fans
- Compressors

Additional advantages:

- High availability through automatic restart and flying restart after power failures
- Broken belt detection by monitoring the load torque
- Pump protection against cavitation
- Hammer start and blockage clearing modes for clogged pumps
- PID controller for process values (e.g. temperature, pressure, level, flow)
- PID auto tuning to optimize controller parameters
- Hibernation mode stops the motor when demand is low
- Motor staging extends the flow range by adding two more fixed-speed drives (cascade)
- Frost and condensation protection prevents moisture in motors under extreme environmental conditions



Moving

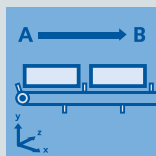

- Belt conveyors
- Roller conveyors
- Chain conveyors

Additional advantages:

- Soft, jerk-free acceleration reduces the stress on the gear units, bearings, drums and rollers
- Super torque start for conveyor belts with high breakaway torque
- Dynamic behavior by using braking resistor or DC braking
- Direct control of mechanical holding brake
- Broken belt detection by monitoring the load torque
- Precise stopping with Quick Stop (switch-off positioning) independently from the control cycle



Processing

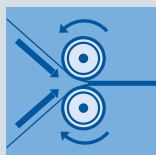

- **Single drives in the process industry** such as mills, mixers, kneaders, crushers, agitators, centrifuges
- **Main drives in machines with mechanically coupled axes** such as ring spinning machines, braiding machines for textile, ropes and wire

Additional advantages:

- Frost and condensation protection prevents moisture in motors under extreme environmental conditions
- Higher productivity with uninterrupted production due to Keep Running Mode
- Exchange of regenerative energy via the DC link
- Super torque start for machines with a high breakaway torque



Easy to install



Installation		
<p>Side-by-side mounting No space required</p> <p>Wall mounting Cooling</p> <p>Push-through mounting Cooling</p>	<p>SINAMICS V20 feature</p> <p>Compact design, side-by-side mounting and flexible device installation for both wall mounting and push-through mounting.</p> <p>Operation without additional option modules possible.</p>	<p>Your benefits</p> <ul style="list-style-type: none"> • Compact installation allows smaller cabinets to be used • Push-through mounting allows the cabinet to be cooled more easily • Can be run "out-of-the-box" without other options • Basic operator actions at a built-in BOP (Basic Operator Panel)

Communication		
<p>Siemens products Standard library USS</p> <p>Other products SINAMICS V20 Modbus</p>	<p>SINAMICS V20 feature</p> <p>The communication port is available at the terminals. The preset parameters of the USS and Modbus RTU are defined in the connection macro.</p>	<p>Your benefits</p> <ul style="list-style-type: none"> • Easy integration into existing systems • Easy integration into micro automation systems • Easier commissioning through standard libraries and connection macros • Full flexibility of Modbus RTU settings widen to communicate with controller

Braking module		
<p>SINAMICS V20</p> <p>Motor</p> <p>Braking module</p> <p>Resistor</p>	<p>SINAMICS V20 feature</p> <p>The dynamic energy is dissipated as heat in a braking resistor with an adjustable duty cycle of between 5% and 100%.</p>	<p>Your benefits</p> <ul style="list-style-type: none"> • Possible to use dynamic braking to increase braking performance • Inverters ≥ 7.5 kW have an integrated braking module. In this case, the braking resistor can be directly connected.

Easy to use

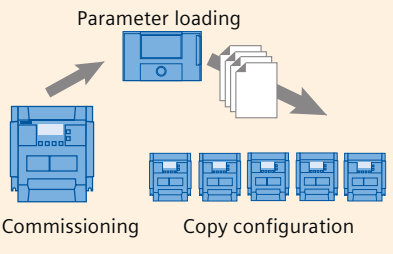
Parameter cloning		
	SINAMICS V20 feature	Your benefits
 <p>Parameter loading</p> <p>Commissioning Copy configuration</p>	<p>Parameter settings can be easily transferred from one unit to another using the BOP (Basic Operator Panel) interface – or even without power supply by using the parameter loader.</p>	<ul style="list-style-type: none"> • Less technical support required • Short commissioning time • The product is delivered to the customer already preset

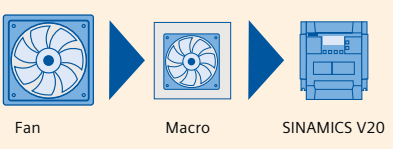
Macro approach		
	SINAMICS V20 feature	Your benefits
 <p>Fan Macro SINAMICS V20</p>	<p>Connection and application macros to simplify I/O configuration and make the appropriate settings.</p>	<ul style="list-style-type: none"> • Shorter training and commissioning time • Integrated and optimized application setting • Simple connection and application macros can be selected instead of configuring long complicated parameter lists • Errors caused by wrong parameter settings can be avoided

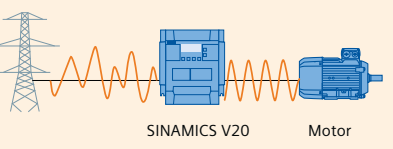
Keep Running Mode		
	SINAMICS V20 feature	Your benefits
 <p>SINAMICS V20 Motor</p>	<p>The function provides higher productivity in production by automatic adaptation in the case of unstable line supplies.</p>	<ul style="list-style-type: none"> • Stable operation under difficult line supply conditions • Higher productivity through prevention of interruptions of the production line • Adaptation to application-relevant reactions through flexible definition in case of fault/alarm

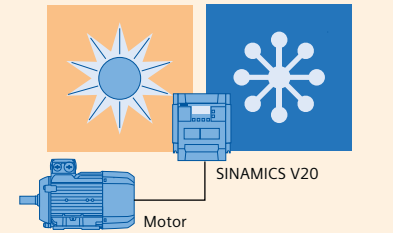
Robustness		
	SINAMICS V20 feature	Your benefits
 <p>SINAMICS V20 Motor</p>	<p>Wider voltage range, better cooling design and coated PCB increase robustness of the drive in difficult environments.</p>	<ul style="list-style-type: none"> • Operation possible when the line supply voltage fluctuates • Reliable operation for line voltages: <ul style="list-style-type: none"> – 1AC 200 V ... 240 V (-10% / +10%) – 3AC 380 V ... 480 V (-15% / +10%) • Operation up to an ambient temperature of 60 °C

Easy to save money

Energy reduction during operation



1)

SINAMICS V20 feature

Integrated ECO mode for V/f and V²/f automatically adapts the flux to save energy. The energy consumption can be shown in kWh, CO₂ or even in the local currency.

Your benefits

- Energy saving during low dynamic load cycles
- If the setpoint changes, the ECO mode is automatically deactivated
- Tells end users the actual energy that has been saved

Energy reduction during operation – DC coupling

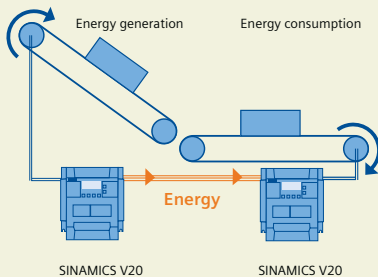

SINAMICS V20 feature

Applications that use SINAMICS V20 drives with the same power rating can share a common DC bus to reuse the regenerative energy.

Your benefits

- Generate and save energy in applications that use coupled motors
- Pairs of identical inverters can optimally share resources
- Reduce the need for dynamic braking and external components

Energy reduction during standby – hibernation mode

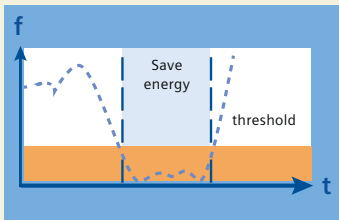

SINAMICS V20 feature

Inverter and motor only operate when the plant or machine requires them to. Hibernation mode will be activated automatically when the frequency demand or the feedback from a sensor drops below a specific threshold.

Your benefits

- Smart hibernation saves energy
- Extended lifetime of motor
- Reduced pump wear at low speed
- Less time to program PLC code for pump/fan applications (PLC)

Cost saving at low overload application

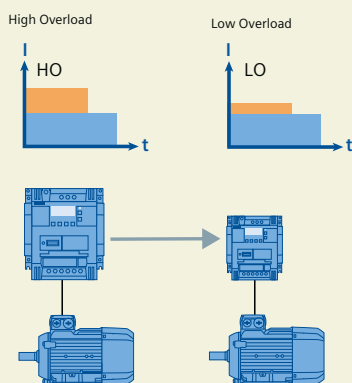

SINAMICS V20 feature

SINAMICS V20 FSE (22 kW and 30 kW) integrated two different load cycles.

- Low Overload (LO): 110% I_L² for 60 s (cycle time: 300 s)
- High Overload (HO): 150% I_H³ for 60 s (cycle time: 300 s)

Your benefits

- With low overload cycle, the inverter can reach a higher output current and power. A smaller inverter can be used.
- Optimally designed for variable applications:
 - Low Overload for applications with a low dynamic response (continuous duty)
 - High Overload for applications with a high dynamic response (cyclic duty)

¹⁾ Application and machine-type dependent.

²⁾ The output current I_L is based on the duty cycle for low overload (LO).

³⁾ The output current I_H is based on the duty cycle for high overload (HO).

Easy automation system

Combining SIMATIC PLC with SINAMICS V20

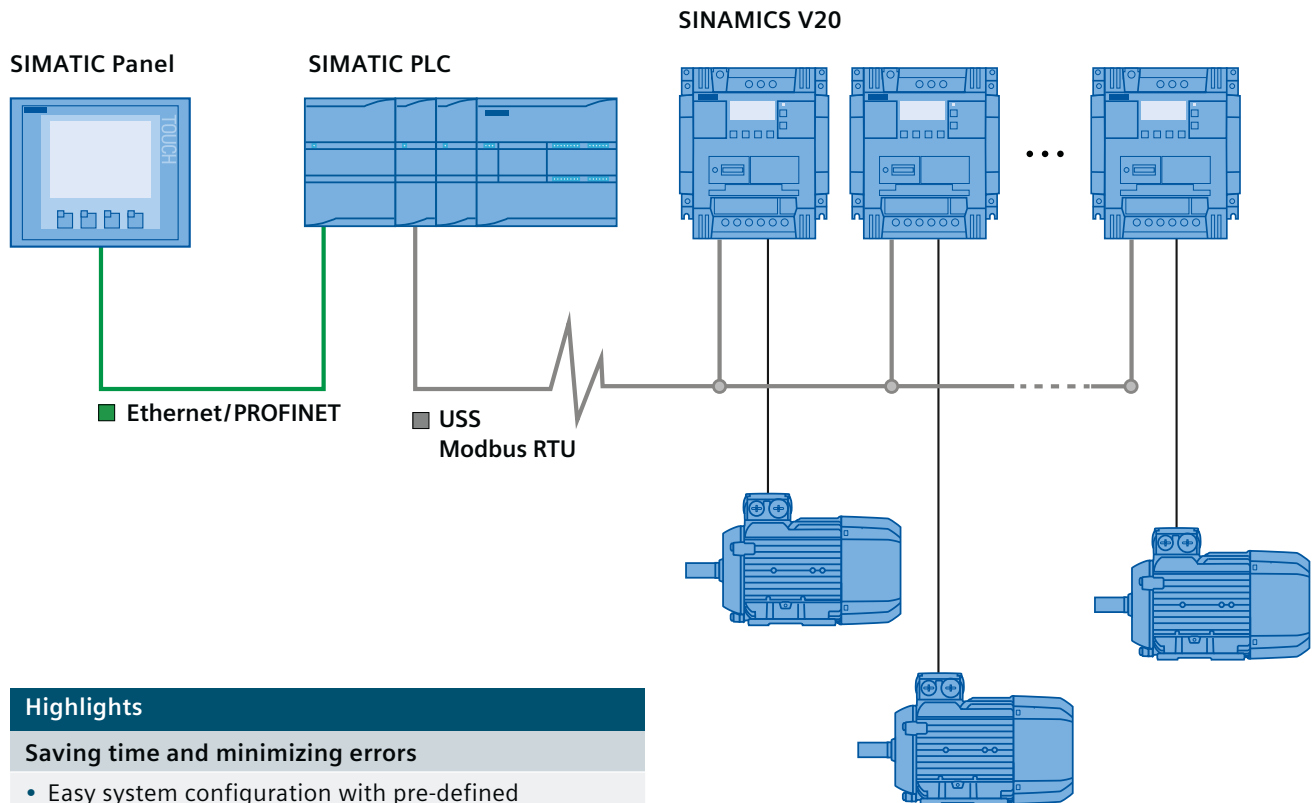

Highlights

Saving time and minimizing errors

- Easy system configuration with pre-defined macros in the inverter and pre-built Totally Integrated Automation Portal function blocks for quick connection to SIMATIC S7-1200**
- One cable to connect SINAMICS V20 with USS or Modbus RTU
- Integrated communication interface

** Application example with function blocks can be downloaded from Siemens Industry Online Support under:
<http://support.automation.siemens.com/WW/view/en/63696870>



Overload capability characteristics

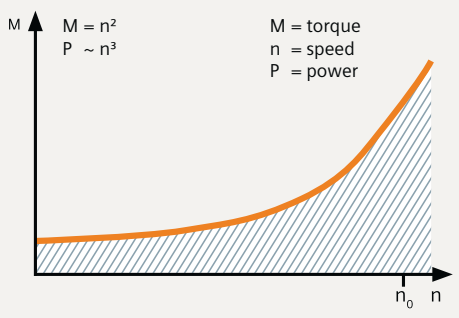

$M = n^2$
 $P \sim n^3$

$M = \text{torque}$
 $n = \text{speed}$
 $P = \text{power}$

Low Overload (LO) is generally used for applications demanding a low level of dynamic performance (continuous duty), square-law torque characteristic with low breakaway torque and low speed precision.

For example: centrifugal pumps, radial/axial fans, reciprocating blowers, radial compressors, vacuum pumps, agitators, ...

Overload capability	
Low overload (LO)	110% $I_L^{(1)}$ for 60 s within a cycle time of 300 s

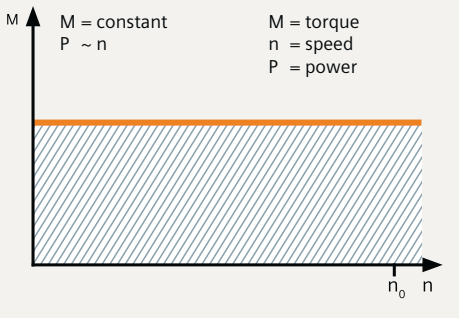

$M = \text{constant}$
 $P \sim n$

$M = \text{torque}$
 $n = \text{speed}$
 $P = \text{power}$

High Overload (HO) is generally used for applications demanding a higher dynamic performance (cyclic duty) as well as constant torque characteristics with a high breakaway torque.

For example: conveyor belts, geared pumps, eccentric worm pumps, mills, mixers, crushers, vertical conveying equipment, centrifuges, ...

Overload capability	
High overload (HO)	150% $I_H^{(2)}$ for 60 s within a cycle time of 300 s

¹⁾ The output current I_L is based on the duty cycle for low overload (LO).

²⁾ The output current I_H is based on the duty cycle for high overload (HO).

SINAMICS V20 service

SINAMICS V20 service is integrated into our well-established global model.

- Global hotline support
- Comprehensive service network of factory-trained repair specialists
- Multiple language web-based support and FAQs

Online Support

The comprehensive online information platform supports you in all aspects of our service & support at any time and from any location in the world.

[siemens.com/automation/service&support](https://www.siemens.com/automation/service&support)

Technical support

Expert advice on technical questions with a wide range of demand-optimized services for all our products and systems.

Country	Hotline
China	+86 400 810 4288
Germany	+49 911 895 7222
India	+91 22 2760 0150
USA	+1 423 262 5710 / +1 800 333 7421

Further service contact information: Support contacts
[siemens.com/automation/support-request](https://www.siemens.com/automation/support-request)

Full range of options

Everything you need...

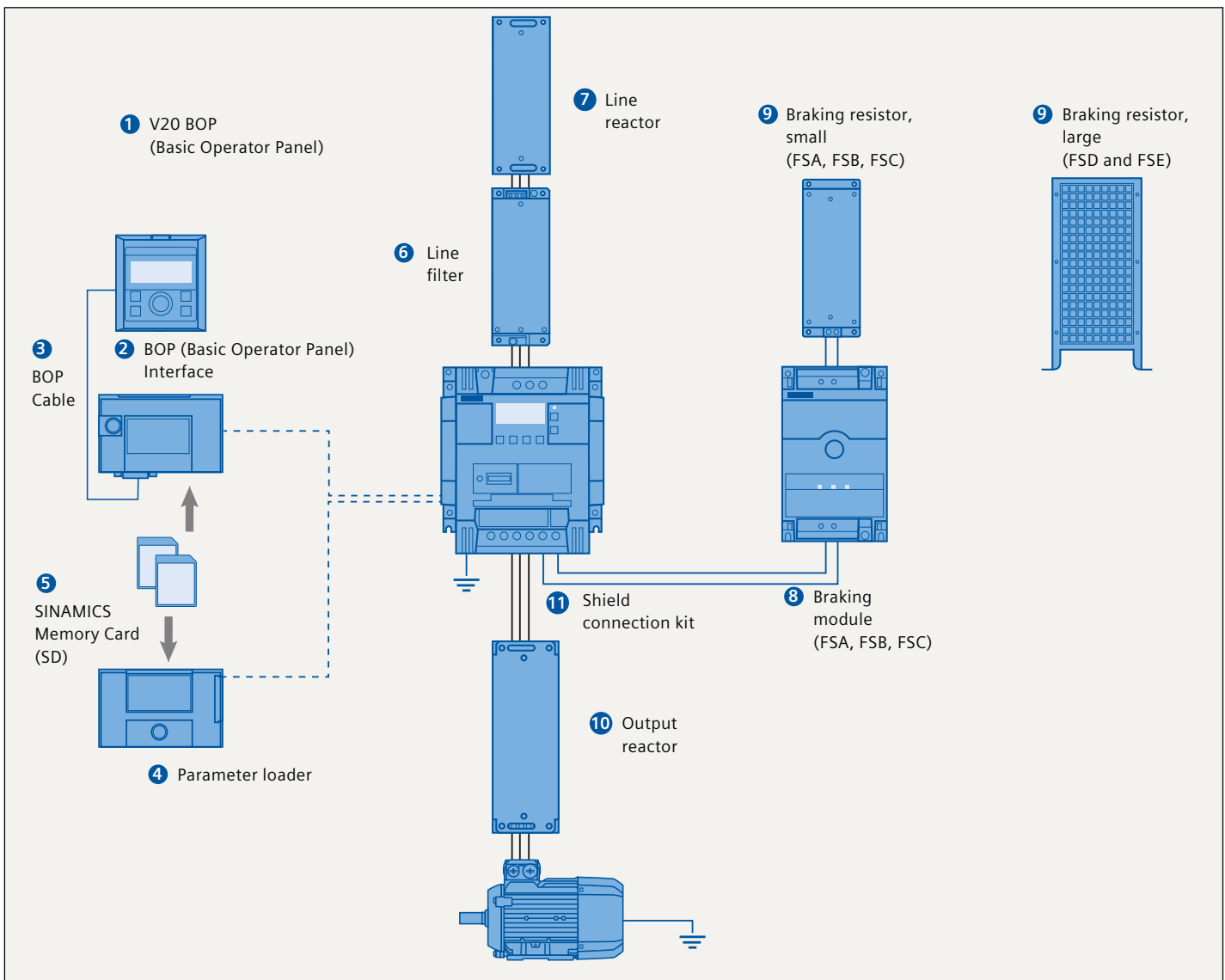

Options		
1	V20 BOP	Same function as the integrated BOP (Basic Operator Panel), but can be used for remote mounting. The value and setpoint are changed by rotating the wheel.
2	BOP interface	<ul style="list-style-type: none"> • Connection between inverter and BOP • Integrated SD/MMC card slot for parameter cloning
3	BOP cable	3 m cable with connectors
4	Parameter loader	Up to 100 parameter sets with parameter settings can be written from the memory card to the inverter or saved from the inverter to the memory card without connecting the inverter to the line supply.
5	SINAMICS Memory Card (SD)	Memory card
6	Line filter	<ul style="list-style-type: none"> • Improved EMC performance • Longer motor cable for FSA

Options		
7	Line reactor	<ul style="list-style-type: none"> • Reduces the harmonic current • Improves the power factor • Recommended if input current (RMS value) is higher than the rated current of the inverter
8	Braking module	<ul style="list-style-type: none"> • Shortens the deceleration ramp time • Suitable for 1AC 230 V and 3AC 400 V • Adjustable duty cycle from 5% to 100% • FSD and FSE already have an integrated braking unit
9	Braking resistor	<ul style="list-style-type: none"> • Dissipates regenerative energy as heat • 5% duty cycle as default setting
10	Output reactor	Longer motor cable: <ul style="list-style-type: none"> • 3AC 400 V shielded and unshielded cable: 150 m • 1AC 230 V shielded and unshielded cable: 200 m
11	Shield connection kit	<ul style="list-style-type: none"> • Shield connection • Strain relief

Technical data



Power and control	
Voltage	1AC 230 V: 1AC 200 V ... 240 V (-10% ... +10%) 3AC 400 V: 3AC 380 V ... 480 V (-15% ... +10%)
Maximum output voltage	100% of input voltage
Supply frequency	50 / 60 Hz
Line supply type	TN, TT, TT earthed line, IT ¹⁾
Power range	1AC 230 V 0.12 ... 3.0 kW (1/6 ... 4 hp) 3AC 400 V 0.37 ... 30 kW (1/2 ... 40 hp)
cos φ / Power factor	≥ 0.95 / 0.72
Overload capability	up to 15 kW: High Overload (HO): 150% I _H for 60 s within a cycle time of 300 s from 18.5 kW: Low Overload (LO): 110% I _L for 60 s within a cycle time of 300 s High Overload (HO): 150% I _H for 60 s within a cycle time of 300 s
Output frequency	0 ... 550 Hz resolution: 0.01 Hz
Efficiency factor	98%
Control modes	Voltage / frequency control mode: linear V/f, square law V/f, multi-point V/f Flux current control mode: FCC
Standards	
Standards	CE, cULus, C-tick, KC
EMC standards, radiated emissions and disturbance voltage (conducted emissions)	EN61800-3 category C2, 1st environment (domestic premises): <ul style="list-style-type: none"> 1AC 230 V with integrated line filter, shielded cables ≤ 25 m (FSA ≤ 10 m²⁾) 3AC 400 V without integrated line filter with external line filter, shielded cables FSA up to FSD ≤ 25 m, FSE ≤ 50 m EN61800-3 category C3, 2nd environment (industrial premises): <ul style="list-style-type: none"> 3AC 400 V with integrated line filter, shielded cables FSA ≤ 10 m, FSB up to FSD ≤ 25 m, FSE ≤ 50 m
Features	
Energy saving	<ul style="list-style-type: none"> ECO mode Hibernation mode Energy consumption monitoring
Ease of use	<ul style="list-style-type: none"> Connection and application macro Parameter cloning Keep Running Mode USS/Modbus RTU communication Customized default value List of modified parameters Inverter status at fault Automatic restart Flying start DC-link voltage control I_{max} control
Application	<ul style="list-style-type: none"> PID controller BICO function Hammer start Super torque mode Blockage clearing mode Motor staging Flexible boost control Wobble function Slip compensation Dual ramp Adjustable PWM modulation
Protection	<ul style="list-style-type: none"> Frost protection Condensation protection Cavitation protection Kinetic buffering Load failure detection

¹⁾ Only 3AC 400V unfiltered devices can be operated at IT Network.

²⁾ To achieve 25 m shielded motor cable length also with FSA, unfiltered devices with external filter have to be used.

Signal inputs and outputs	
Analog inputs	A11: bipolar current / voltage mode A12: unipolar current / voltage mode Can be used as digital inputs
Analog outputs	A01: 0 ... 20 mA
Digital inputs	DI1–DI4, optically isolated PNP/NPN selectable by terminal
Digital outputs	DO1: transistor output DO2: relay output – 250 V AC 0.5 A with resistive load – 30 V DC 0.5 A with resistive load

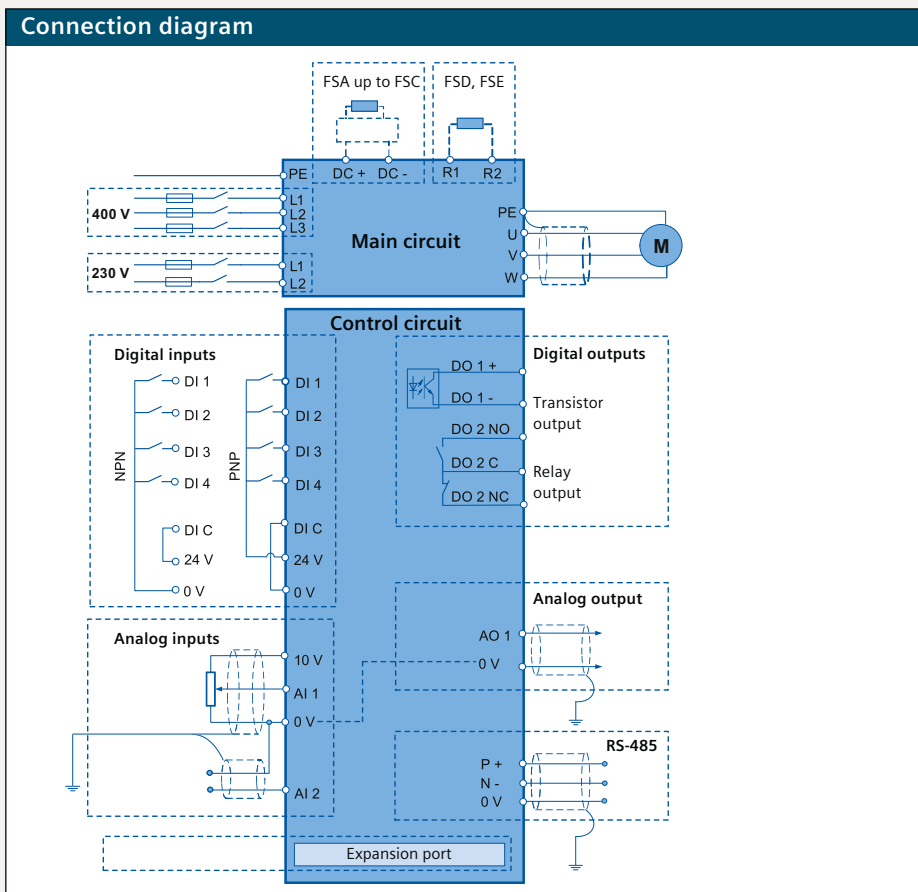

Mounting and environment	
Degree of protection	IP20
Mounting	Wall mounting, side-by-side mounting, push-through mounting for FSB, FSC, FSD and FSE
Cooling	<ul style="list-style-type: none"> FSA up to 0.75 kW: convection cooling FSA up to FSE: power electronics cooled using heat sinks with external fan
Ambient temperature	In operation <ul style="list-style-type: none"> –10 ... 60 °C (14 ... 140 °F) 40 ... 60 °C (104 ... 140 °F) with derating In Storage <ul style="list-style-type: none"> –40 ... 70 °C (–40 ... 158 °F)
Relative humidity	95% (non-condensing)
Altitude	<ul style="list-style-type: none"> Up to 4000 m above sea level 1000 ... 4000 m: output current derating 2000 ... 4000 m: supply voltage derating
Motor cable length	<ul style="list-style-type: none"> Unshielded cable : 50 m for FSA up to FSD, 100 m for FSE Shielded cable: 25 m for FSA up to FSD, 50 m for FSE Longer motor cables possible with output reactor (see options)
Dynamic braking	Option module for FSA, FSB and FSC; integrated for FSD and FSE

Dimensions

SINAMICS V20 device

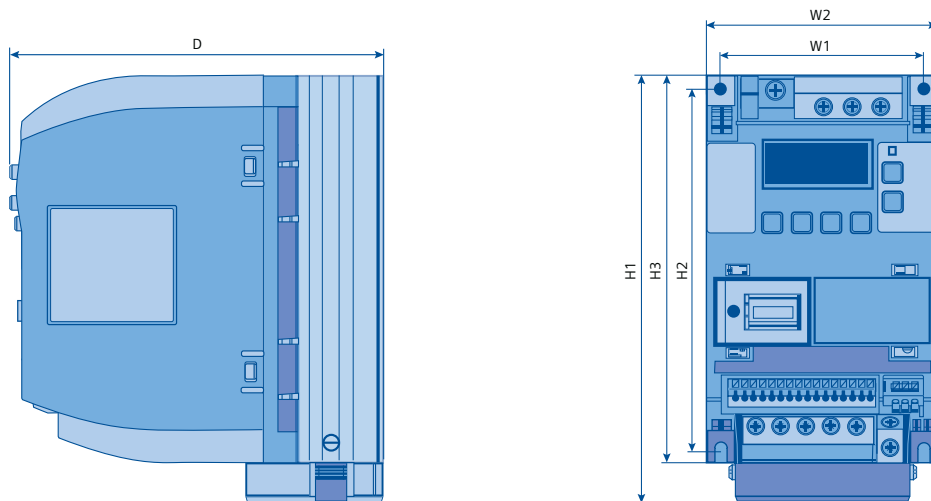

Frame size	Width (mm)		Height (mm)			Depth (mm)	Weight (kg)
	W1	W2	H1	H2	H3		
FSA without fan	79	90	–	140	150	145.5	1
FSA	79	90	166	140	150	145.5	1.05
FSB	127	140	160	135	–	164.5	1.8
FSC	170	184	182	140	–	169	2.6
FSD	223	240	206.5	166	–	172.5	4.3
FSE	228	243.5	264.5	206	–	209	6.6

V20 BOP (Basic Operator Panel)

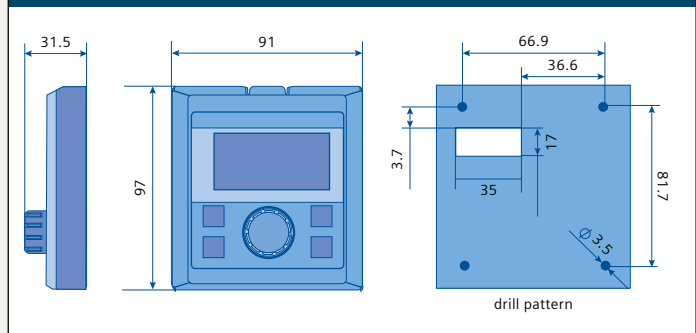

BOP (Basic Operator Panel) interface

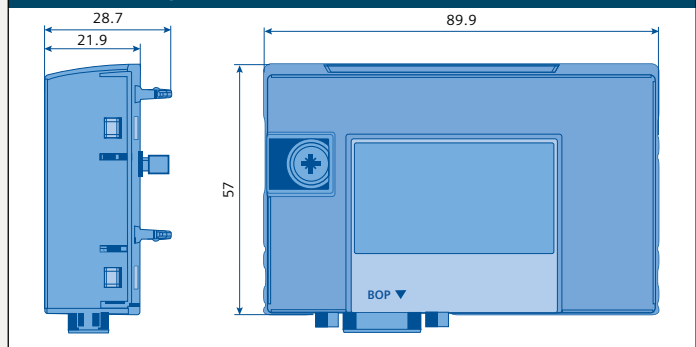

Parameter loader

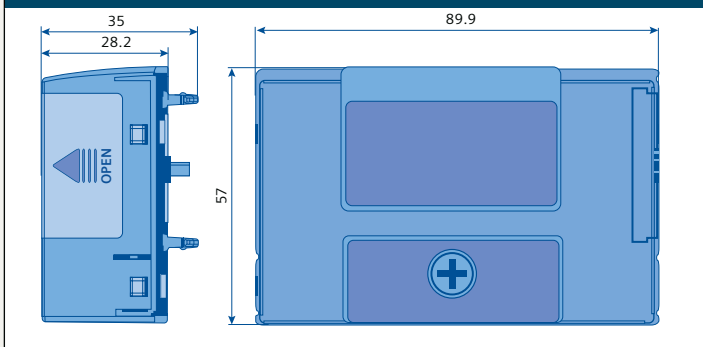

Dimensions

1AC 230 V options

P _{rated} (HO) kW 1AC 230 V	FS	Braking resistors				Line reactors				Output reactors				Braking module				Line filter class B			
		W	H	D	WT	W	H	D	WT	W	H	D	WT	W	H	D	WT	W	H	D	WT
0.12	A	72	230	43.5	1	75.5	200	50	1.4	75	200	50	1.3	90	150	88	0.71	73	200	43.5	0.5
0.25																					
0.37																					
0.55																					
0.75																					
1.1	B	149	239		1.6	150	213		2.2	150	213	80	4.1					149	213	50.5	1
1.5																					
2.2	C																				
3																					
3		185	285	150	3.8	185	245		5.1	185	245		6.6								

3AC 400 V options

P _{rated} (LO) kW 3AC 400 V	FS	Braking resistors				Line reactors				Output reactors				Braking module				Line filter class B			
		W	H	D	WT	W	H	D	WT	W	H	D	WT	W	H	D	WT	W	H	D	WT
0.37	A	105	295	100	1.48	125	120	71	1.1	207	175	73	3.4	90	150	80	0.71	73	202	65	1.75
0.55																					
0.75																					
1.1																					
1.5																					
2.2	B	105	345	100	1.80	125	140	71	2.1	207	180	73	3.9								
3																					
4																					
5.5	C	175	345	100	2.73	125	145	91	2.95	247	215	100	10.1								
7.5																					
11	D	250	490	140	6.20	190	220	91	7.8	257	235	115	11.2	integrated				140	359	95	7.3
15																					
22																					
30	E	270	515	175	7.4	300	620	85	9.5	250	280	250	11.3					260	180	600	7.3
						320	800	95	17												

FS = frame size, WT = weight in kg, W = width in mm, H = height in mm, D = depth in mm

Simple entry using the DT Configurator

The DT Configurator supports you with:

- Selecting the drive based on the application
- The subsequent ordering process

DT Configurator supplies you with

- A drive that is optimally tailored to your requirements
- 2D/3D models
- Operating instructions
- Data sheets

You can directly order the selected components through the Industry Mall – the Siemens e-commerce website – and without having to duplicate entries. In order to avoid making ordering mistakes, the order number is checked to ensure that it is correct. [siemens.com/dt-configurator](https://www.siemens.com/dt-configurator)

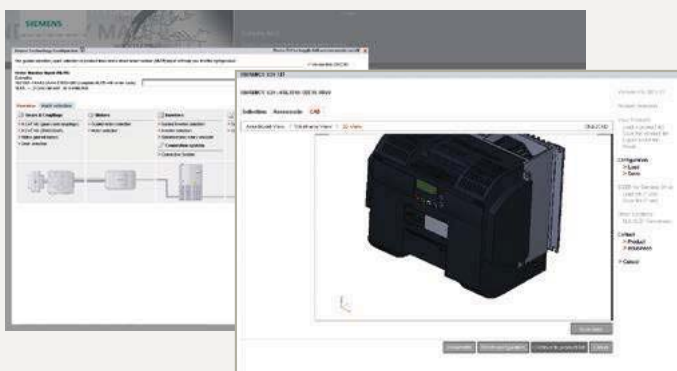

SINAMICS
SELECTOR App –
find article
numbers quickly
and easily



Scan the QR code
and download the
SINAMICS SELECTOR App
free of charge

Ordering data

1AC 230 V device

Rated data							
P _{rated} (HO)		I _H	Article number	Fans	Frame size		
kW	hp	A					
0.12	1/6	0.9	6SL3210-5BB11-2	V0	–	FSA	
0.25	1/3	1.7	6SL3210-5BB12-5	V0	–		
0.37	1/2	2.3	6SL3210-5BB13-7	V0	–		
0.55	3/4	3.2	6SL3210-5BB15-5	V0	–		
0.75	3/4	3.9	6SL3210-5BB17-5	V0	–		
0.75	1	4.2	6SL3210-5BB18-0	V0	1	FSB	
1.1	1–1/2	6	6SL3210-5BB21-1	V0	1		
1.5	2	7.8	6SL3210-5BB21-5	V0	1	FSC	
2.2	3	11	6SL3210-5BB22-2	V0	1		
3	4	13.6	6SL3210-5BB23-0	V0	1		
EMC Standards							
With integrated line filter category C2							A
Without integrated filter							U

3AC 400 V device

Rated data							
P _{rated} (LO)		I _L 400 V ¹⁾	I _L 480 V	P _{rated} (HO)		I _H 400 V ²⁾	I _H 480 V
kW	hp	A	A	kW	hp	A	A
0.37	1/2	1.3	1.3	0.37	1/2	1.3	1.3
0.55	3/4	1.7	1.7	0.55	3/4	1.7	1.7
0.75	1	2.2	2.2	0.75	1	2.2	2.2
1.1	1–1/2	3.1	3.1	1.1	1–1/2	3.1	3.1
1.5	2	4.1	4.1	1.5	2	4.1	4.1
2.2	3	5.6	4.8	2.2	3	5.6	4.8
3	4	7.3	7.3	3	4	7.3	7.3
4	5	8.8	8.24	4	5	8.8	8.24
5.5	7–1/2	12.5	11	5.5	7–1/2	12.5	11
7.5	10	16.5	16.5	7.5	10	16.5	16.5
11	15	25	21	11	15	25	21
15	20	31	31	15	20	31	31
22	30	45	40	18.5	25	38	34
30	40	60	52	22	30	45	40

EMC Standards

With integrated line filter category C3

Without integrated filter

¹⁾ The output current I_L is based on the duty cycle for low overload (LO).

²⁾ The output current I_H is based on the duty cycle for high overload (HO).

1AC 230 V options

FS	P _{rated} (HO) kW	Braking resistor 6SE6400-...	Line reactor 6SE6400-...	Output reactor 6SE6400-...	Shield connection kit 6SL3266-...	Line filter class B ³⁾ 6SE6400-...	Corresponding to the IEC standard		
							Standard fuse ⁴⁾		Circuit breaker ⁴⁾
							Current in A	Article No.	Article No.
A	0.12	4BC05-0AA0	3CC00-4AB3	3TC00-4AD3	1AA00-0VA0	2FL01-0AB0	10	3NA3803	3RV2011-1DA10
	0.25						10	3NA3803	3RV2011-1FA10
	0.37						10	3NA3803	3RV2011-1HA10
	0.55						10	3NA3803	3RV2011-1JA10
	0.75						16	3NA3805	3RV2011-1KA10
B	1.1	4BC11-2BA0	3CC02-6BB3	3TC01-0BD3	1AB00-0VA0	–	20	3NA3807	3RV2021-4BA10
	1.5						32	3NA3812	3RV2021-4CA10
C	2.2	4BC12-5CA0	3CC03-5CB3	3TC03-2CD3	1AC00-0VA0	–	35	3NA3814	3RV1031-4EA10
	3						50	3NA3820	3RV1031-4FA10

3AC 400 V options

FS	P _{rated} (LO) kW	P _{rated} (HO) kW	Braking resistor 6SL3201-...	Line reactor 6SL3203-...	Output reactor 6SL3202-...	Shield connection kit 6SL3266-...	Line filter class B ³⁾ 6SL3203-...	Corresponding to the IEC standard		
								Standard fuse ⁴⁾		Circuit breaker ⁴⁾
								Current in A	Article No.	Article No.
FSA	0.37	0.37	OBE14-3AA0	OCE13-2AA0	OAE16-1CA0	1AA00-0VA0	OBE17-7BA0	6	3NA3801	3RV2011-1CA10
	0.55	0.55						6	3NA3801	3RV2011-1DA10
	0.75	0.75						6	3NA3801	3RV2011-1EA10
	1.1	1.1						6	3NA3801	3RV2011-1FA10
	1.5	1.5						10	3NA3803	3RV2011-1HA10
	2.2	2.2						16	3NA3805	3RV2011-1JA10
FSB	3	3	OBE21-0AA0	OCE21-0AA0	OAE18-8CA0	1AB00-0VA0	OBE21-8BA0	16	3NA3805	3RV2011-4AA10
	4	4						20	3NA3807	3RV2021-4AA10
FSC	5.5	5.5	OBE21-8AA0	OCE21-8AA0	OAE23-8CA0	1AC00-0VA0	–	3NA3810	3RV2021-4BA10	
FSD	7.5	7.5	OBE23-8AA0	OCE23-8AA0	OAE23-8CA0	1AD00-0VA0	OBE23-8BA0	–	–	–
	11	11						–	–	–
	15	15						–	–	–
			6SE6400-...	6SE6400-...	6SE6400-...	6SL3266-...	6SL3203-...			
FSE	22	18.5	4BD21-2DA0	3CC05-2DD0	3TC05-4DD0	1AE00-0VA0	OBE23-8BA0	–	–	–
	30	22		3CC08-3ED0	–			–	–	

³⁾ See specification of EMC standards, page 10

⁴⁾ Additional information about the listed fuses and circuit breakers can be found in Catalogs LV 10, IC 10 and IC 10 A0
siemens.com/drives/infocenter

Article number	Fans	Frame size
6SL3210-5BE13-7	V0	–
6SL3210-5BE15-5	V0	–
6SL3210-5BE17-5	V0	–
6SL3210-5BE21-1	V0	1
6SL3210-5BE21-5	V0	1
6SL3210-5BE22-2	V0	1
6SL3210-5BE23-0	V0	1
6SL3210-5BE24-0	V0	1
6SL3210-5BE25-5	V0	1
6SL3210-5BE27-5	V0	2
6SL3210-5BE31-1	V0	2
6SL3210-5BE31-5	V0	2
6SL3210-5BE31-8	V0 New	2
6SL3210-5BE32-2	V0 New	2

C

U

Spare parts

Frame size	Article number
Replacement fan	
FSA	6SL3200-0UF01-0AA0
FSB	6SL3200-0UF02-0AA0
FSC	6SL3200-0UF03-0AA0
FSD	6SL3200-0UF04-0AA0
FSE	6SL3200-0UF05-0AA0

Accessories

Name	Article number
Parameter loader	6SL3255-0VE00-0UAA0
BOP (Basic Operator Panel) interface	6SL3255-0VA00-2AA0
Braking module 1AC 230 V: 8 A 3AC 400 V: 7 A	6SL3201-2AD20-8VA0
V20 BOP (Basic Operator Panel)	6SL3255-0VA00-4BA0
BOP cable 3 m incl. 4 mounting screws	6SL3256-0VP00-0VA0
SINAMICS Memory Card (SD)	6SL3054-4AG00-2AA0
RS485 Terminators (Content 50 Pieces)	6SL3255-0VC00-0HA0
SINAMICS V20 Democase	6AG1067-2AA00-0AB6
DIN Rail Mounting Kit	FSA: 6SL3261-1BA00-0AA0 ⁵⁾ FSB: 6SL3261-1BB00-0AA0

⁵⁾ Installation of FSA with fan pls. refer to SINAMICS V20 manual.



Industry Services

Your machines and plants can do more

Siemens supports its customers worldwide with Services for products, systems and applications throughout the entire lifecycle of machines and plants. Customers benefit not only from our holistic service portfolio, but also from our extensive knowledge of technologies and products, as well as the industry competence of Siemens experts.

With the product-related services in particular, the focus is always on ensuring maximum plant availability in daily operation. The key here is expert consulting and support directly from the manufacturer of the drive and automation technology being used.

As a result downtimes are reduced and resource utilization is optimized. The result is greater productivity, flexibility and efficiency at a lower overall cost.

Discover all the advantages of the Industry Services portfolio at [siemens.com/industry-services](https://www.siemens.com/industry-services)

There's more to it
siemens.com/ids

Discover in detail how
Integrated Drive Systems
boost your competitive
edge and improve
your time to profit.

Integrated
Drive Systems
to go: Visit our
mobile site!



Subject to change without prior notice
Article No.: E20001-A90-P670-V4-7600
Dispo 21500
WÜ/60750 V6.MKSINA.WES
WS 11147.0
Printed in Germany
© Siemens AG 2014

The information provided in this brochure contains merely general descriptions or characteristics of performance which in case of actual use do not always apply as described or which may change as a result of further development of the products. An obligation to provide the respective characteristics shall only exist if expressly agreed in the terms of contract.

All product designations may be trademarks or product names of Siemens AG or supplier companies whose use by third parties for their own purposes could violate the rights of the owners.

Follow us on:
www.twitter.com/siemensindustry
www.youtube.com/siemens

Siemens AG
Digital Factory
P.O. Box 31 80
91050 Erlangen
GERMANY