

SUPERMOON

Powering modern work and life

Order at 訂貨熱線 :

香港批發 / 分銷 T (852) 2781 2855

澳門批發 / 分銷 T (853) 2822 2751

工程 / 商業項目 T (852) 2691 9166

E enquiry@supermoon.hk

www.supermoon.hk



力雄金屬製品有限公司

LIK HUNG METAL MANUFACTURING

■ PRODUCT CATALOGUE

U 型槽骨架

U CHANNEL

U 槽配件

U CHANNEL ACCESSORIES

2016 EDITION

Care • Commitment • Expertise 盡心 • 承諾 • 專業

Since 1985, Lik Hung has been supplying premium Electrical and Cable Containment Products in Hong Kong and China. Our clients associate LH with fast production, high quality and a comprehensive product offering. In 1991, we were appointed one of the major suppliers to The Hong Kong Housing Authority (HA) and The Architectural Service Department (ASD), opening up limitless opportunities in key housing and government projects. We continue to upgrade our capabilities in 2015 when we invested in a new warehouse, tripling our storage area in Hong Kong.

In 1992, we established a production site in Dongguan with a factory consisting of over 10,000 m² in floor area, expanding our production capabilities to over 18,000 tons per year – an equivalent of 50 tons a day. Further expansions in 2007 added 8000 m² of floor area - not only does this facilitate space for up to 250 staff members but it also allows us to employ top-of-the-line machinery.

Today, with care, commitment and expertise, Lik Hung continues to develop and aim to bring more superior cable containment solutions and reliable services to our customer. In fact, we've never stopped improving since we began our journey.

我們自1985年推出'力雄'電線槽及U槽系列以來，以ISO9001:2000為生產規範，其質優價廉，配套齊備，一直深受各界樂於採用。1991年更被香港政府指定為香港房屋協會及工務局工程用料供應商之一，積極參與無數政府及房協工程。我們2015年繼續改進，把香港倉擴展到大三倍的葵涌地舖倉，大大增加存貨和送貨量。

自1992年移師東莞生產，及後2007年的擴建，我們的產量增長至每年18,000噸 - 相等於每天50噸的貨物。合共18,000平方米的廠房配合超過250名的員工，運用先進的電腦化板金機械成型設備，進一步改善生產技術及交貨時間。

今天，一路貫徹著'力雄'的宗旨 - 盡心，承諾及專業，我們不斷致力改進從而提供一些更優質的產品方案及服務給我們的顧客。



■Material:	Mild steel Stainless steel grade 304 or 316 complying with ASTM A240 / A240M - 08	■原料：	高級鋼板 不銹鋼 304 或 316符合 ASTM A240 / A240M - 08
■Standard:	Meets BS 6946	■規格：	符合BS 6946
■Length:	Standard length of 3m / 6m, other lengths available on request	■長度：	標準 3m / 6m, 其他長度可按照客需要
■Thickness:	2.5mm, 2.0mm	■厚度：	2.5mm, 2.0mm
■Finishes:	Hot dip galvanized to BS 729, ISO 1460, ISO 1461 Coloured Epoxy powder coating	■表面處理：	熱浸鋅符合英國標準 BS 729, ISO 1460, ISO 1461 顏色聚脂油粉

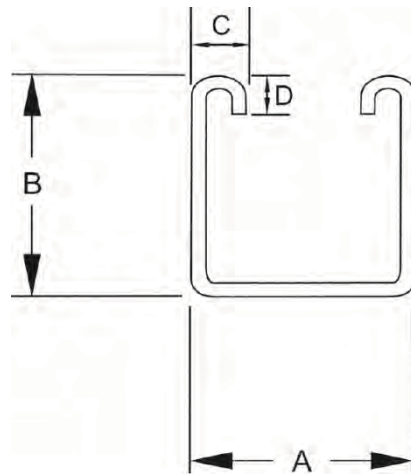

D = 7mm
C = 10mm
B = 21/41mm
A = 41mm

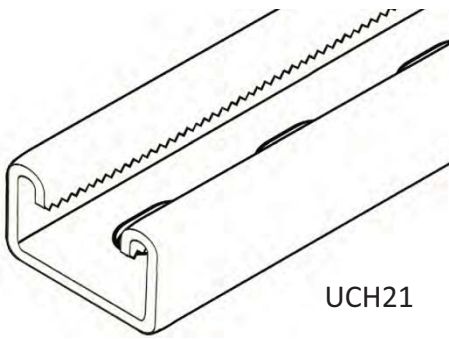

UCH21

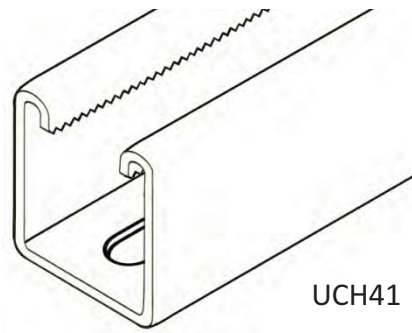

UCH41

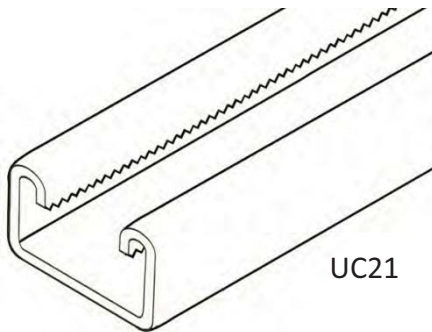

UC21

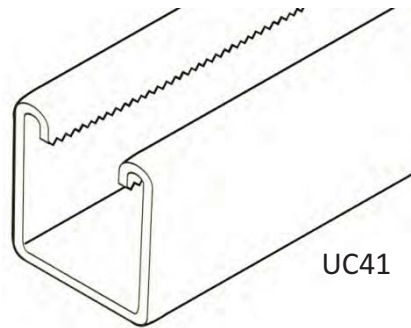

UC41

Model	尺寸 Size	開孔 Slotted	重量 Weight kg/m
UCH21	21x41mm	14x28mm at 50mm centres	1.76
UCH41	41x41mm	14x28mm at 50mm centres	2.73
UC21	21x41mm	/	1.91
UC41	41x41mm	/	2.88

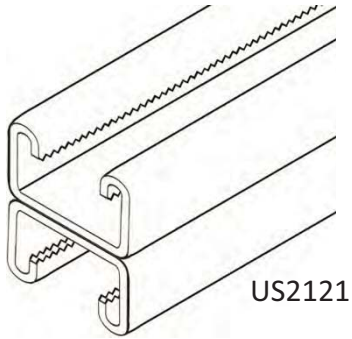

US2121

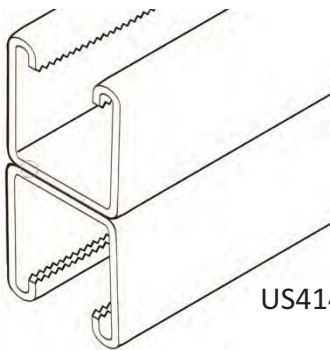
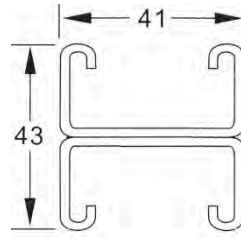

US4141

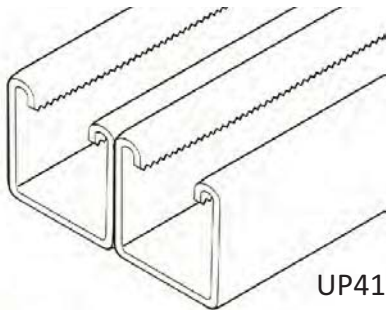
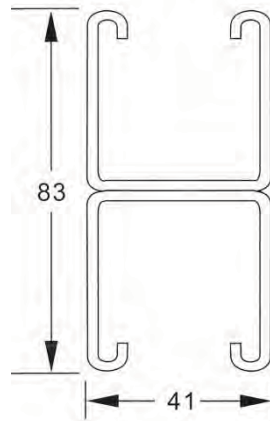

UP4141

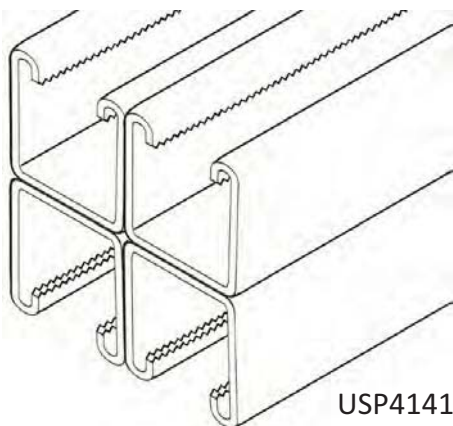
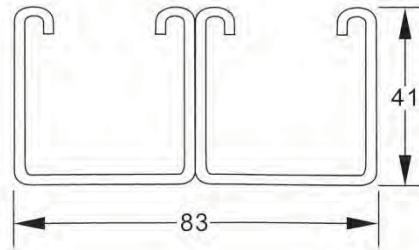

USP4141

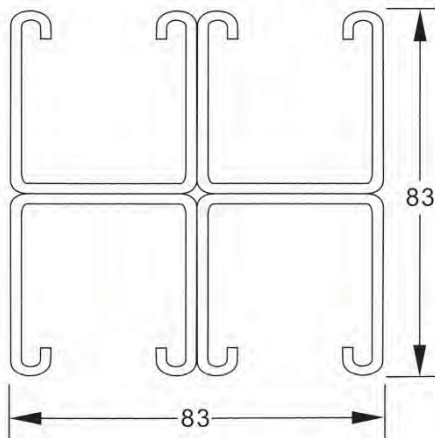

特款組合也可按照要求製造
Custom combinations can be produced under client request

■ **Material:** Steel plates, strip or coil

Stainless steel grade 304 or 316

■ **原料:** 鋼板, 鋼條及鋼卷片

不銹鋼 304 或 316

■ **Thickness:** 6mm

■ **厚度:** 6mm

■ **Finishes:** Hot dip galvanized to
BS 729, ISO 1460, ISO 1461

Other finishes can be supplied on request

■ **表面處理:** 熱浸鋅符合英國標準
BS 729, ISO 1460, ISO 1461

其他的表面處理可按照要求製造

■ **Hole size** Standard 14mm diameter

Other sizes can be produced on request

■ **標準面孔直徑:** 14mm

其他尺寸可按照要求製造

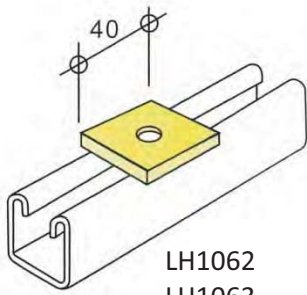

LH1062
LH1063
LH1064

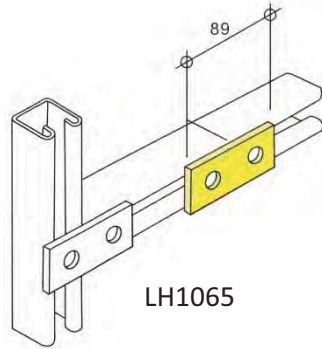

LH1065

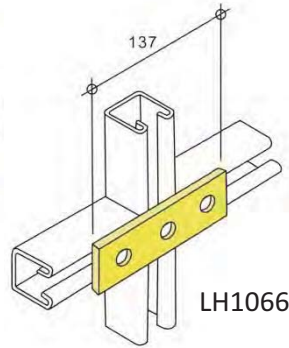

LH1066

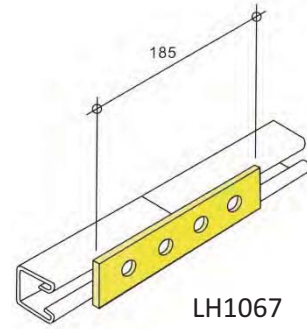

LH1067

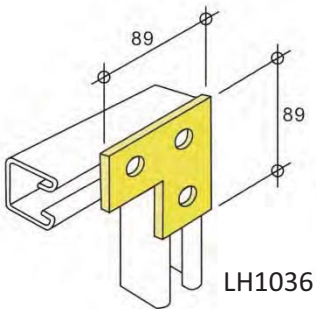

LH1036

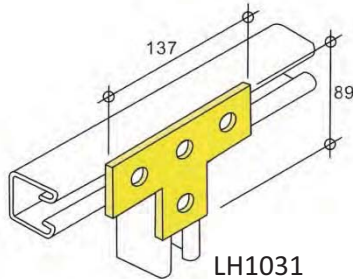

LH1031

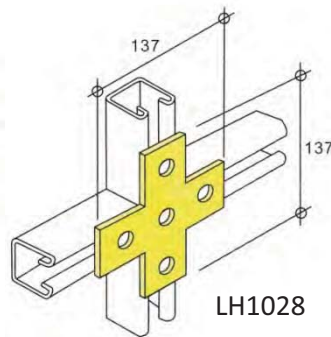

LH1028

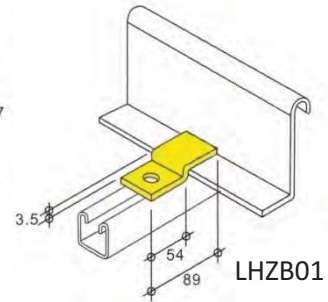

LHZB01

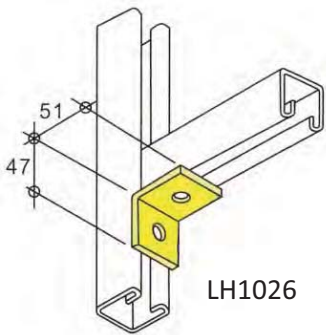

LH1026

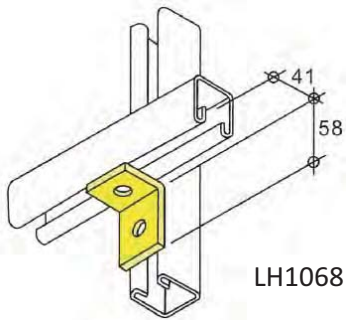

LH1068

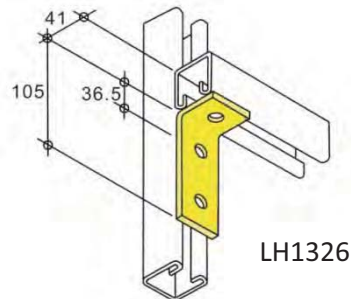

LH1326

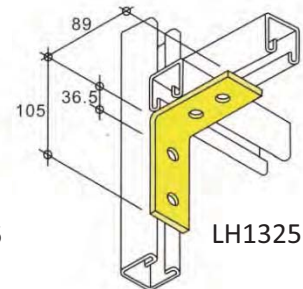

LH1325

Model	重量 Weight (g)	孔尺寸 Hole Diameter
LH1062	73	9mm / M8
LH1063	72	11mm / M10
LH1064	69	14mm / M12
LH1065	157	14mm
LH1066	243	14mm
LH1067	330	14mm
LH1036	250	14mm

Model	重量 Weight (g)	孔尺寸 Hole Diameter
LH1031	339	14mm
LH1028	425	14mm
LHZB01	160	14mm
LH1026	157	14mm
LH1068	159	14mm
LH1326	242	14mm
LH1325	327	14mm

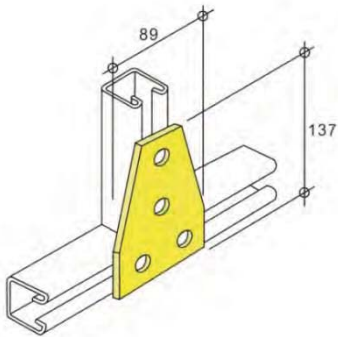

LH1358 - weight 450g

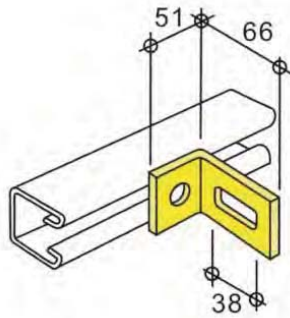

LH1749 - weight 194g

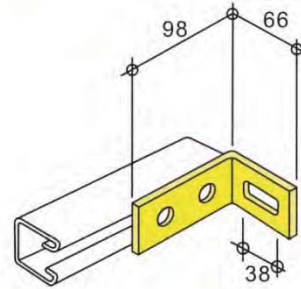

LH1747 - weight 263g

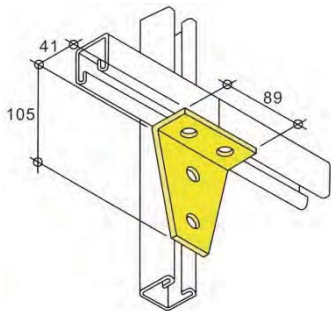

LH1359 - weight 458g

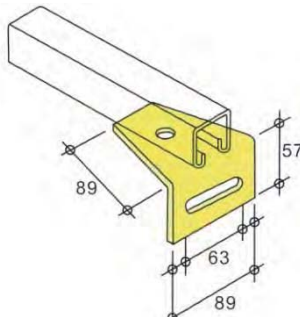

LH1713 - weight 384g

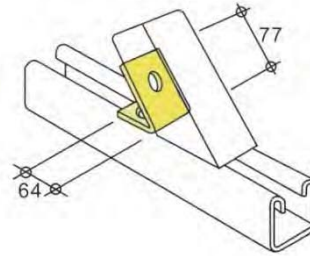

LH1186-45° - weight 256g

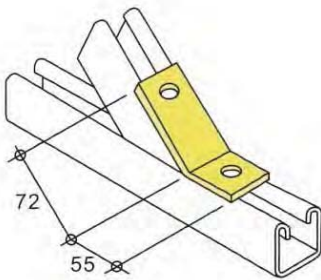

LH1546-45° - weight 243g

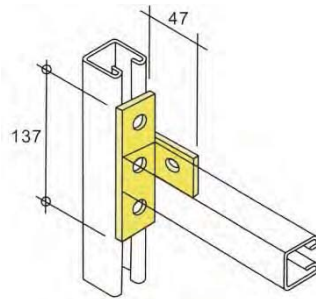

LH1033 - weight 342g

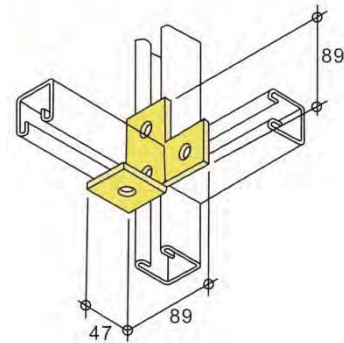

LH1035 - weight 342g

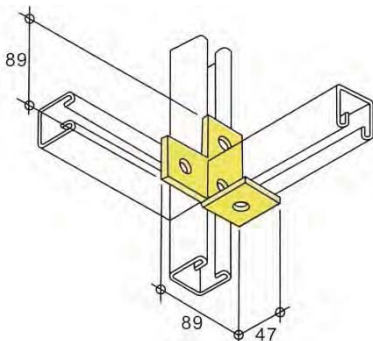

LH1034 - weight 342g

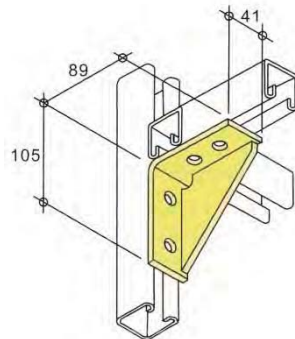

LH1331 - weight 432g

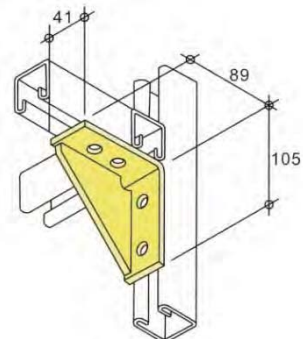

LH1332 - weight 432g

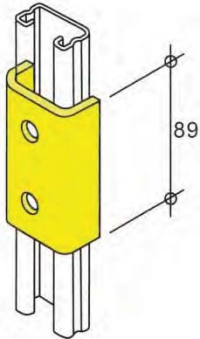

LH4376 - weight 358g

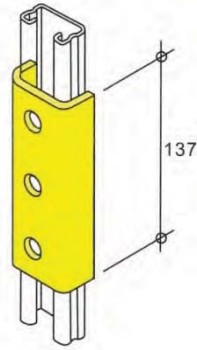

LH4376-A - weight 558g

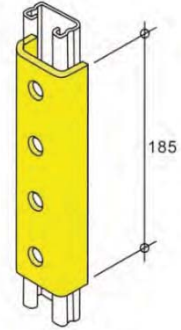

LH4377 - weight 760g

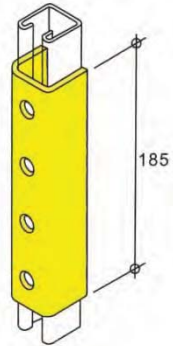

LH1377 - weight 1109g

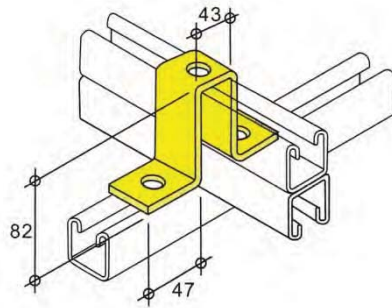

LH1737 - weight 530g

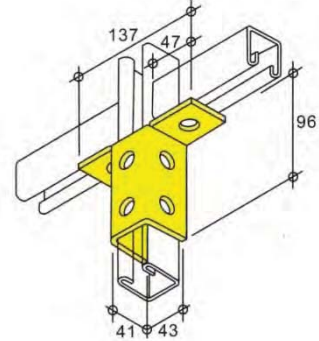

LH2346 - weight 726g

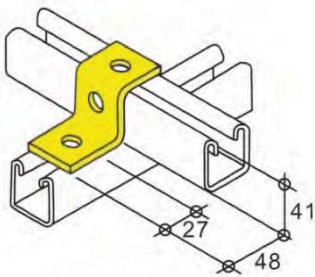

LH1045 - weight 212g

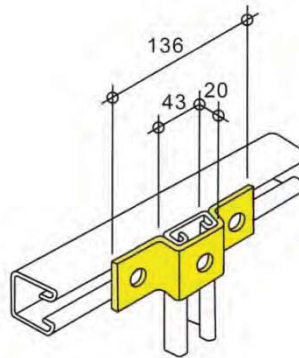

LH4047 - weight 284g

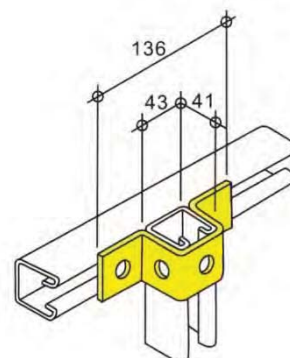

LH1047 - weight 358g

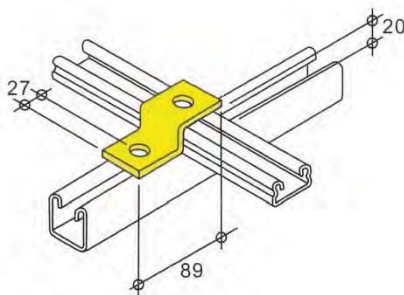

LH4045 - weight 180g

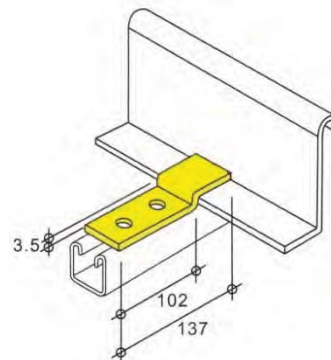

LHZB04 - weight 251g

U型槽骨配件 Fittings and accessories

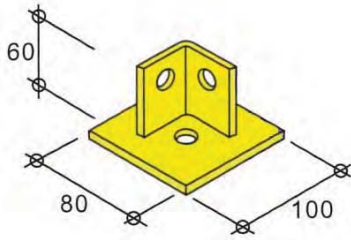

LH2072/S1 - weight 568g

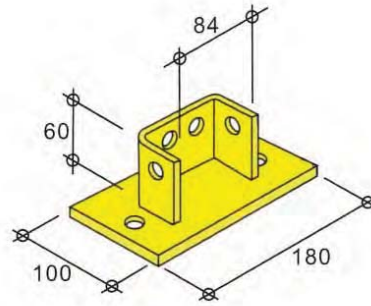

LH2073/A - weight 1927g

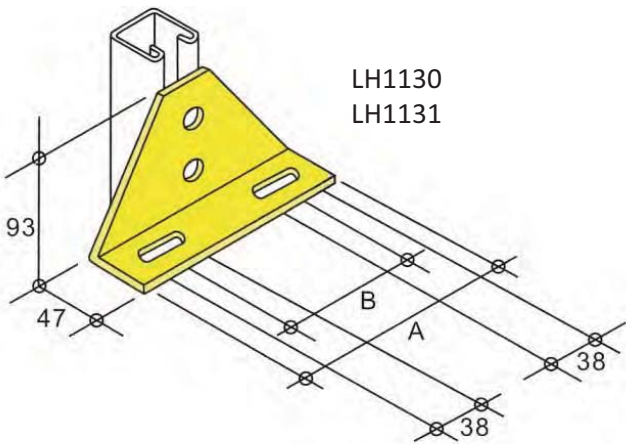

LH1130
LH1131

型號 Model	A (mm)	B (mm)	重量 Weight (g)
LH1130	168	102	760
LH1131	219	152	976

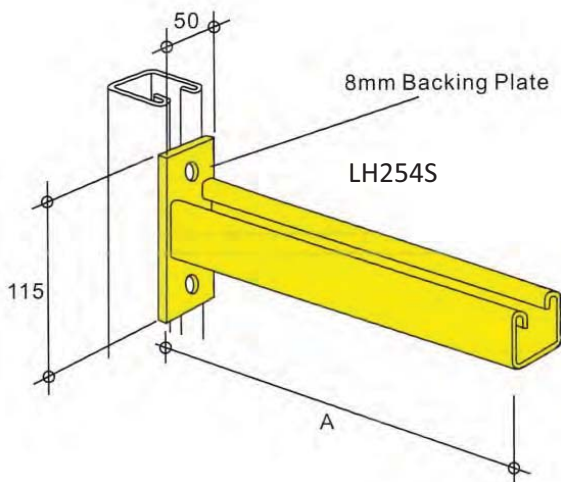

8mm Backing Plate

LH254S

LH254S 長度 Length mm (A)	LH 254S 重量 Weight (g)	均勻分布荷載 Uniformly distributed load (kg)
150	914	477
200	1050	358
250	1186	286
350	1457	204
450	1728	159
550	1999	130
600	2135	119
650	2270	110

特款尺寸也可按照要求製造
Custom sizes can be produced under client request

絲干 Threaded Rod (P.13.)

六角絲母 Hex Nut (P.14.)

平介 Flat Washer (P.14.)

方介 Square washer (P.7.)

彈弓絲母 Spring Nut (P.12.)

尾□ End Cap (P.13.)

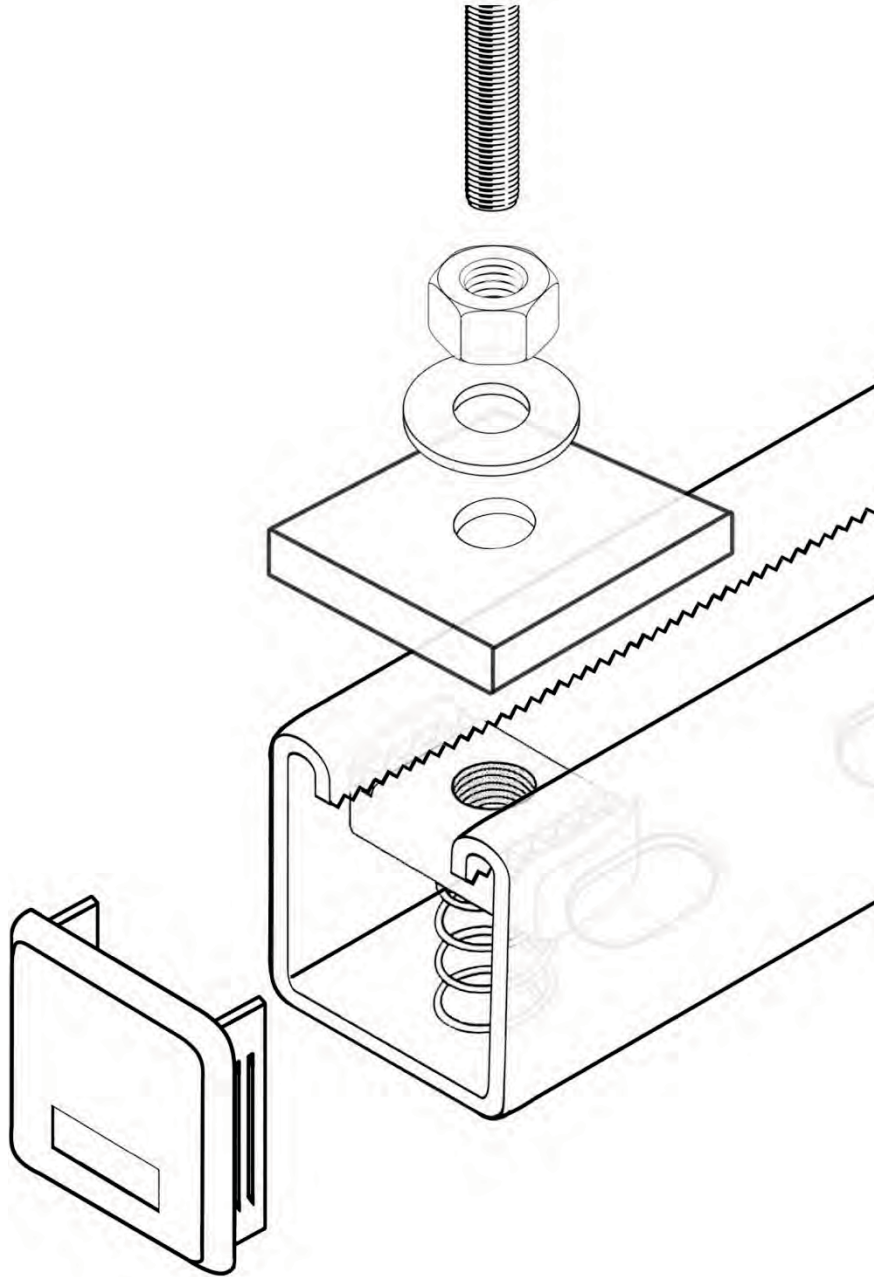

圖片只是安裝例子

Diagram is a suggested example installation only

彈弓絲母 Spring Nut

■ Size: 3/8" , M6, M8, M10, M12

■ 標準直徑: 3/8" , M6, M8, M10, M12

■ Material: Stainless steel 304 / 316 , Mild Steel Zinc electroplated / Mild Steel Hot dip galvanized to BS 729, ISO 1460, 1461

■ 材料 / 表面: 304 / 316 不銹鋼, 電鍍鋅鋼 / 熱浸鋅鋼符合英國標準 BS 729, ISO 1460, 1461

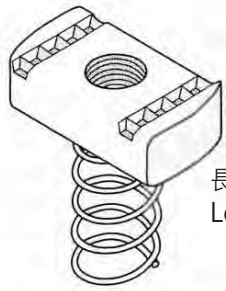

長彈弓
Long Spring

絲紋 Thread Size	彈弓長度 Spring Length	套裝連螺絲: Set comes with screw:	型號 (電鍍鋅) Model Number (Zinc Electroplated)
3/8"	36	-	SPN-L3
M6	36	M6x25 (圓頭 Pan Head)	SPN-L6
M8	36	M8x25 (圓頭 Pan Head)	SPN-L8
M10	36	M10x25 (六角 Hex head)	SPN-L10
M12	36	M12x25 (六角 Hex head)	SPN-L12

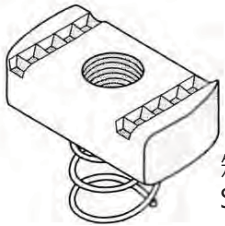

短彈弓
Short Spring

3/8"	16	-	SPN-S3
M6	16	M6x20 (圓頭 Pan Head)	SPN-S6
M8	16	M8x20 (圓頭 Pan Head)	SPN-S8
M10	16	M10x20 (六角 Hex head)	SPN-S10
M12	16	M12x20 (六角 Hex head)	SPN-S12

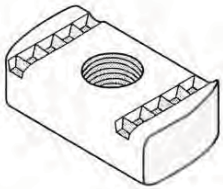

淨絲母
Anti slip nut

3/8"	0	-	SPN3
M6	0	-	SPN6
M8	0	-	SPN8
M10	0	-	SPN10
M12	0	-	SPN12

特款尺寸也可按照要求製造

Custom sizes can be produced under client request

絲干 Threaded Rod

■ Size: 3/8" , M6, M8, M10, M12

■ 標準直徑: 3/8" , M6, M8, M10, M12

■ Material: Stainless steel 304 / 316 , Mild Steel Zinc electroplated / Mild Steel Hot dip galvanized to BS 729, ISO 1460, 1461

■ 材料 / 表面: 304 / 316 不銹鋼, 電鍍鋅鋼 / 熱浸鋅鋼符合英國標準 BS 729, ISO 1460, 1461

■ Length: 3m

■ 長度: 3米



絲干 Threaded Rod

絲紋 Thread Size	重量 Weight (g)	型號 (電鍍鋅) Model Number (Electroplated)
3/8"	1450	TRM3
M6	460	TRM6
M8	920	TRM8
M10	1450	TRM10
M12	2124	TRM12

尾呔 End Cap

■ Colour: Black / white

■ 顏色: 黑 / 白

■ Size: 21x41, 41x41

■ 大小: 21x41, 41x41

■ Material: Plastic

■ 材料: 塑膠

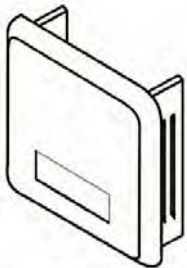

尾呔 End Cap

尺寸 Size (mm)	Model
41x21	UEC21
41x41	UEC41

特款尺寸也可按照要求製造

Custom sizes can be produced under client request

六角絲母 Hex Nut, 平介 Flat Washer, 螺絲 Screw

■ Size: 3/8" , M6, M8, M10, M12

■ 標準直徑: 3/8" , M6, M8, M10, M12

■ Material: 鋼, 304 / 316 不銹鋼

■ 材料: Mild Steel, Stainless steel
304 / 316

■ Screw thread length 8-40mm

■ 螺絲牙長度 : 8-40mm



六角絲母 Hex Nut

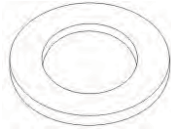

平介 Flat Washer

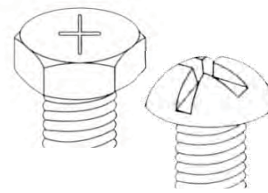

六角 / 圓頭 螺絲
Hex / Pan Head Screw

其他絲干配件 Other Threaded Rod Accessories

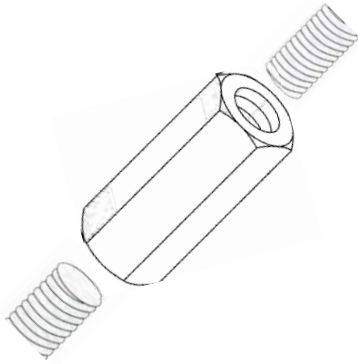

絲干駁
Threaded Rod Coupler

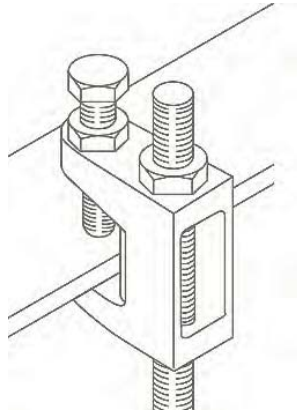

工字夾
Threaded Rod Clamp



敲擊式錨栓 (睜爆)
Drop in Anchor

特款尺寸也可按照要求製造

Custom sizes can be produced under client request

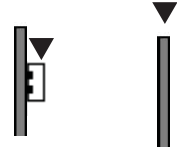
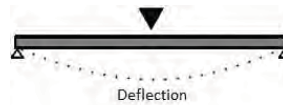

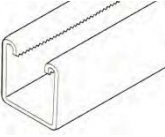
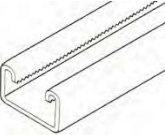
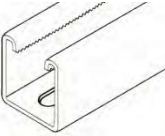
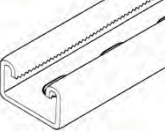

Model	長度 Span (mm)	均勻分佈荷載 Max Uniform beam loading (kN)	相應彎度 Deflection at Uniform load (mm)	中央集中荷載 Max Concentrated load (kN)	相應彎度 Deflection at Concentrated load (mm)	支柱荷載 Eccentric Column Max allowable load at slot face (kN)	頂壓支柱荷載 Concentric Column Max allowable load (kN)
	UC41 610	6.8	1.2	3.4	1.0	14.8	37.7
	914	4.5	3.1	2.3	2.5	13.2	30.4
	1219	3.4	5.9	1.7	4.7	11.4	23.5
	1524	2.7	9.0	1.4	7.2	9.7	18.2
	1829	2.3	12.9	1.1	10.3	8.5	15.0
	2134	1.9	17.2	1.0	13.8	7.5	12.7
	2438	1.7	22.9	0.9	18.3	6.7	13.0
	2743	1.5	29.0	0.8	23.2	6.0	9.7
	3048	1.4	35.8	0.7	28.6	5.4	8.6
	UC21 610	2.3	2.9	1.1	2.3	9.8	29.1
	914	1.5	6.0	0.8	4.8	7.9	22.6
	1219	1.1	10.4	0.6	8.3	5.9	14.0
	1524	0.9	16.5	0.5	13.2	4.5	9.0
	1829	0.8	23.7	0.4	19.0	3.5	6.3
	2134	0.7	32.1	0.3	25.7	2.8	4.1
	2438	0.6	41.7	0.3	33.4	2.3	3.5
	2743	0.5	52.5	0.3	42.0	1.9	-
	3048	0.4	65.4	0.2	52.3	1.6	-
	UCH41 610	5.8	1.2	2.9	1.0	-	-
	914	3.9	3.1	1.9	2.5	-	-
	1219	2.9	5.9	1.5	4.7	-	-
	1524	2.3	9.0	1.1	7.2	-	-
	1829	1.9	12.9	1.0	10.3	-	-
	2134	1.6	17.2	0.8	13.8	-	-
	2438	1.4	22.9	0.7	18.3	-	-
	2743	1.3	29.0	0.7	23.2	-	-
	3048	1.1	35.8	0.6	28.6	-	-
	UCH21 610	2.0	2.9	1.0	2.3	-	-
	914	1.3	6.0	0.7	4.8	-	-
	1219	1.0	10.4	0.5	8.3	-	-
	1524	0.8	16.5	0.4	13.2	-	-
	1829	0.7	23.7	0.3	19.0	-	-
	2134	0.6	32.1	0.3	25.7	-	-
	2438	0.5	41.7	0.2	33.4	-	-
	2743	0.4	52.5	0.2	42.0	-	-
	3048	0.4	65.4	0.2	52.3	-	-

數據只作參考，產品不同應用之下不一定適用

Data is for reference only, may change under different applications of product use

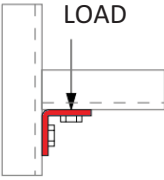
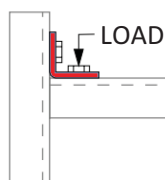
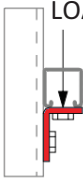
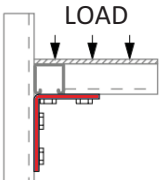
U型槽骨配件 U Channel Fittings

				
LH1026	LH1026	LH1068	LH1325	LH1326
kN	kN	kN	kN	kN
5.7	3.7	1.9	7.6	10.1

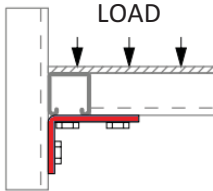
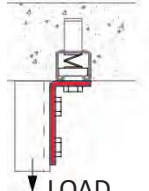
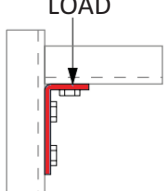
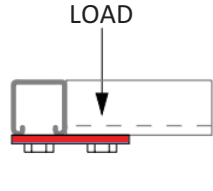
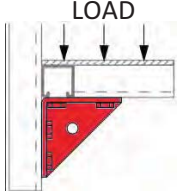
				
LH1326	LH1326	LH1326	LH1065	LH1331/1332
kN	kN	kN	kN	kN
5.7	4.5	7.6	3.7	11.3

數據只作參考, 產品不同應用之下不一定適用

Data is for reference only, may change under different applications of product use





力雄金屬製品有限公司
LIK HUNG METAL MANUFACTURING LTD.



香港

營業部

葵涌 工業街 23-31號
美聯工業大廈 B座地下
電話: (852) 2743 7827
傳真: (852) 2785 7655
電郵地址: sale@likhung.com.hk

青山道分倉

九龍長沙灣
醫局西街1037號匯華大廈6字樓C座

中國大陸

工廠

東莞力雄五金電器塑膠製品有限公司
鳳崗鎮 雁田管理區

www.likhung.hk

Hong Kong

Office

Ground Floor, Unit B,
Mai Luen Industrial Building,
23 - 31 Kung Yip St, Kwai Chung
Tel: (852) 2743 7827
Fax: (852) 2785 7655
Email Address: sale@likhung.com.hk

Warehouse

BLK. C, 6/F., Wui Wah Factory Building, 1037
Yee Kuk West Street, Cheung Sha Wan

Mainland

Factory

Wai Hing Road, Yantian District,
Fenggang Town, China

